

General Description

1.5 Pin Assignments

The MC68HC05K3 is available in 16-pin PDIP, 16-pin SOIC, and 20-pin SSOP packages. The pin assignments for these packages are shown in [Figure 1-1](#), [Figure 1-2](#), and [Figure 1-3](#).

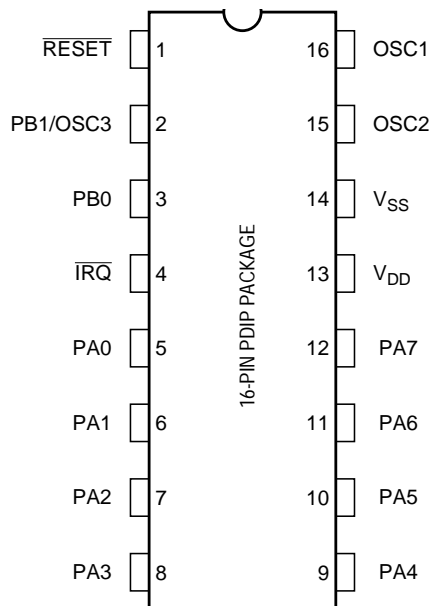

Figure 1-1. Pin Assignments for 16-Pin PDIP

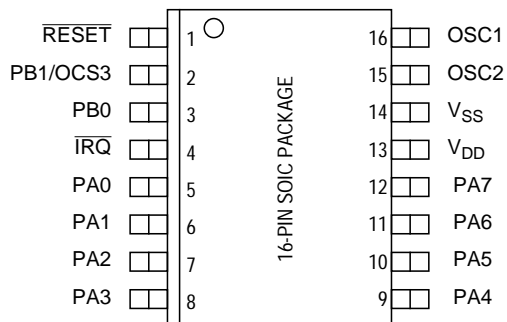

Figure 1-2. Pin Assignments for 16-Pin SOIC

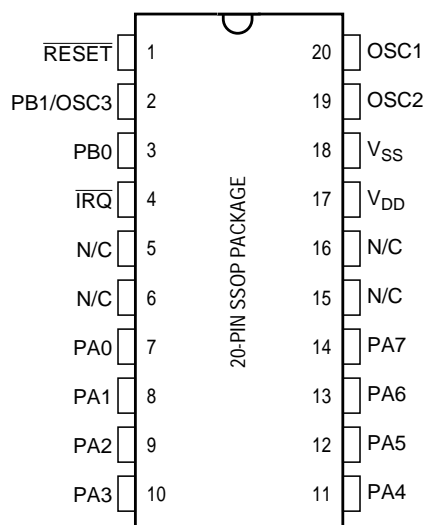

Figure 1-3. Pin Assignments for 20-Pin SSOP

1.6 MCU Structure

The overall block diagram of the MC68HC05K3 is shown in [Figure 1-4](#).

1.7 Functional Pin Description

The following paragraphs give a description of the general function of each pin.

1.7.1 V_{DD} and V_{SS}

Power is supplied to the MCU through V_{DD} and V_{SS}. V_{DD} is the positive supply and V_{SS} is ground. The MCU operates from a single power supply.

Rapid signal transitions occur on the MCU pins. The short rise and fall times place very high short-duration current demands on the power supply. To prevent noise problems, special care should be taken to provide good power supply bypassing at the MCU by using bypass capacitors with high-frequency characteristics that are positioned as close to the MCU as possible.