

2.3 Pin Assignments

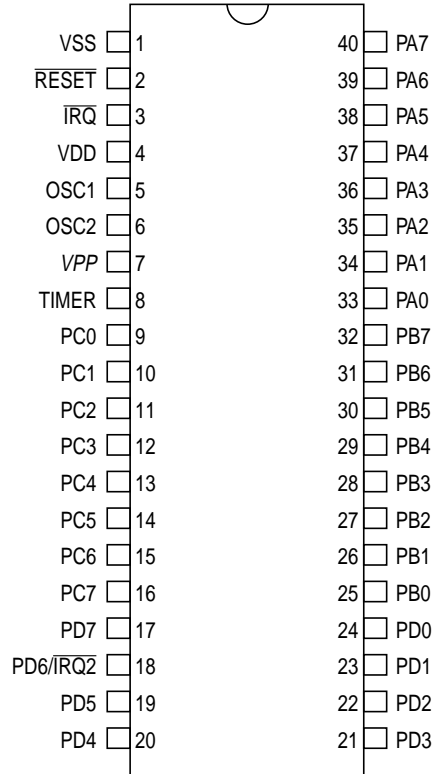

Figure 2-4 Pin Assignment for 40-pin PDIP

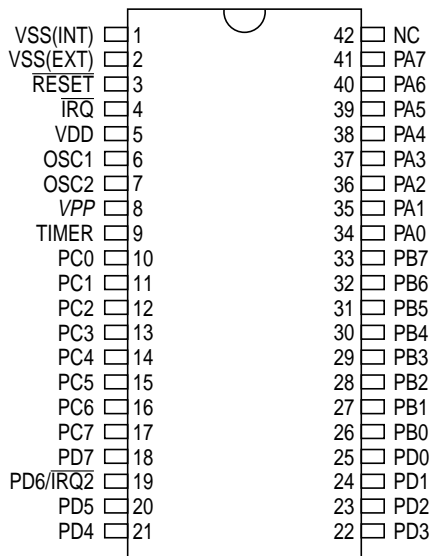

Figure 2-5 Pin Assignment for 42-pin SDIP

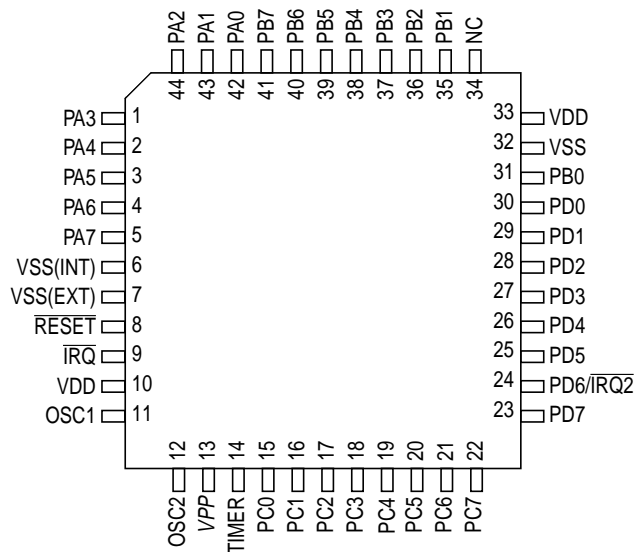

Figure 2-6 Pin Assignment for 44-pin QFP